

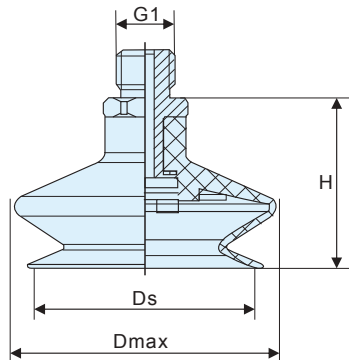

FSGA-6



G1	Dk	Dmax.	Ds	H	mat.	g.	DESC.	Cod.
M5-M	-	8,0	5,7	14,0	NBR-55	2	FSGA-6-1Y12937	78828
M5-M	-	8,0	5,7	14,0	SI-55	2	FSGA-6-1Y12949	79817
M5-M	-	8,0	5,7	14,0	HTI-60	2	FSGA-6-1Y12951	79844

Materials Materiales	Shore hardness Dureza Shore	Flexibility Flexibilidad	Abrasion rest. Rest. a abrasion	UV/Weather rest. Rest. UV/Clima	Oil rest. Rest. a aceites	Heat rest.C° Rango temp.C°	Colour Color
HT1-60: Siton ®	60	+	++	-	++	-40~220°	Blue Azul
SI-55: Silicone	50	+++	-	+++	-	-25~170°	Translucent Tranlucido
NBR-55: Nitrile	60	+	+	-	++	-30~120°	Black Negro