

Slide-off air nippers horizontal-type  
Alicates de corte tipo horizontal

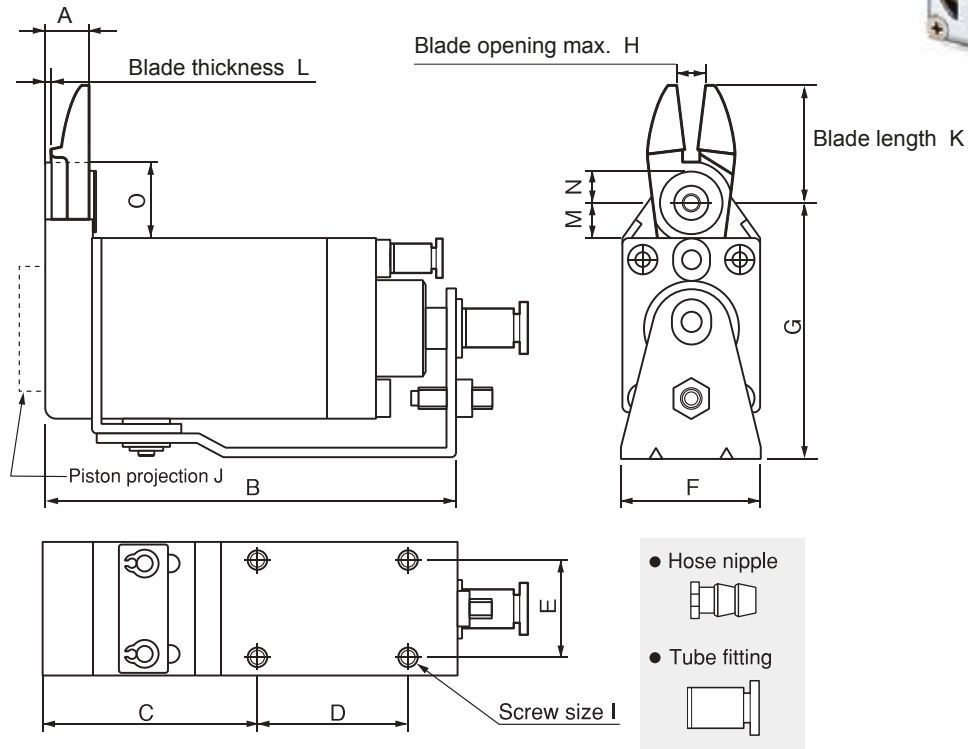

A	B	C	D	E	F	G	H	I	J	K	L	M	N	O	DESC.	Cod.
8,6	75,9	40,9	25	15	23	47,6	4	M4	3	22,0	1,6	8,5	6,25	16,5	<b>GT-NY05</b>	79857
8,8	82,1	42,1	30	20	28	51,6	6	M4	5	24,0	1,6	7,5	6,25	15,5	<b>GT-NY10</b>	79858
12,5	108,5	54,5	40	30	42	69,0	9	M5	2	31,0	2,5	10,5	7	20,5	<b>GT-NY25R-6</b>	79856

Capacity Ø mm.				Air consumption	Weight	DESC.
Soft plastic	Hard plastic	Copper	Stel	1 stroke	g.	
3 max.	2 max.	1,6 max.	1 max.	48 cm <sup>3</sup>	155	<b>GT-NY05</b>
3,5 max.	2,3 max.	-	-	68 cm <sup>3</sup>	210	<b>GT-NY10</b>
5 max.	3,4 max.	-	-	184 cm <sup>3</sup>	580	<b>GT-NY25R-6</b>