

BR5140/2

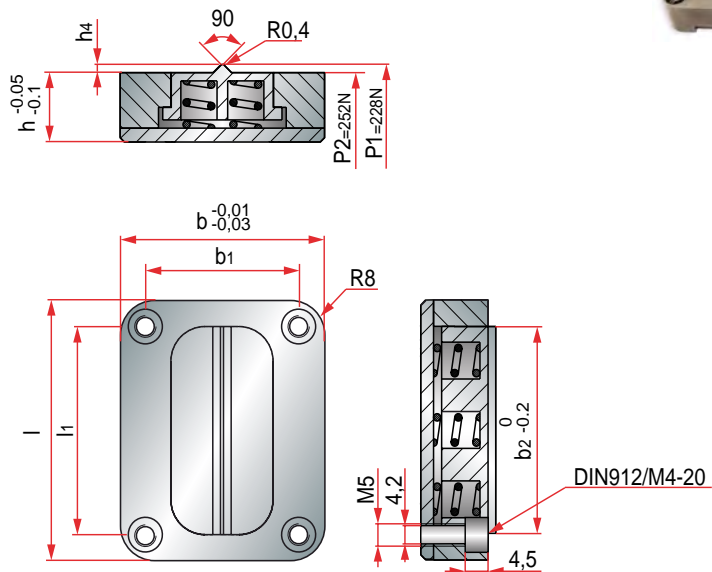

Body mat. : 1.2344. Insert mat. : 1.2379. Hardness: 54 ± 2 HRC. Maximum temperature at work: 100°C .

l1	b1	b2	h4	h	b	l	REF.
44	36	44	1,8	16	48	56	BR5140 / 2

